

Product highlights ▾

- * Linux operation system
- * ARM cpu
- * Digital signal and processor
- * Continuous working 10000 hours above
- * Energy saving design
- * High penetration
- * Good quality images
- * One key turn off
- * Single generator
- * Dual energy with real color images

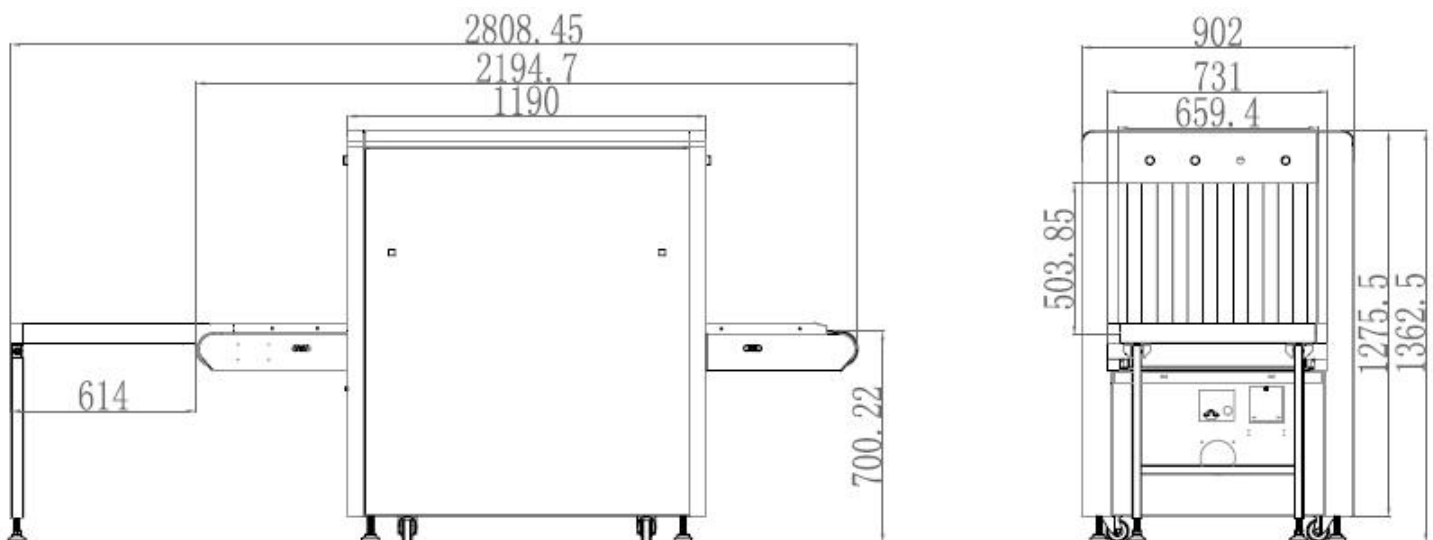

Dimensional Drawing



Important Sizes :

Product Size: 2808.45* 902 *1362.5mm (L × W × H)

Tunnel Size: 659.4* 503.85mm (width × height)

Product Details

General Specifications

Wire Resolution	Typical AWG 40
Penetration resolution	Typical AWG32
Spatial resolution	Vertical: 1.0mm, horizontal: 1.0mm
Penetration	Typical 30mm
Resolution of organic matter	1-120mm
Grayscale and mixture resolution	1-40mm
Resolution of inorganic objects	0.2-14mm
Effective material resolution	Meet the requirements of GB15208.1-2005
X-Ray dosage each inspection	≤2.5μSv (uGy)
Boundary Leakage	≤0.5μSv /h(uGy/h)
S/N ratio	<60dB
Conveyor speed	0.2m/s
Conveyor max load	180kg
Power consumption	0.5KW
Safety performance requirements	Meet the requirements of GB15208.1-2005
EMC requirements	Meet the requirements of GB15208.1-2005
Electrical safety	Meet the requirements of GB15208.1-2005
Environmental applicability	Meet the requirements of GB15208.1-2005
Leakage current	≤5.0mA
Film Safety	Guarantee ASA/ISO1600 Film
Weight	450kg
Operation temperature/Humidity	5°C-40°C/0%-90%
Storage temperature/Humidity	-20°C-60°C /10%-90%
Atmospheric pressure	86kPa-106kPa AC
Operation Power	220V(±10%-15%) 50±3Hz
Operation system	LINUX

General Specifications

X ray generator	140KV, oil cooling, from bottom to top
Electric roller	One- phase
Computer	Hard drive: 500G, Storage : 1G
Monnitor	21.5" LED screen, resolution: 1280*1024 pixels
Operation console	Single screen console

Scanned images

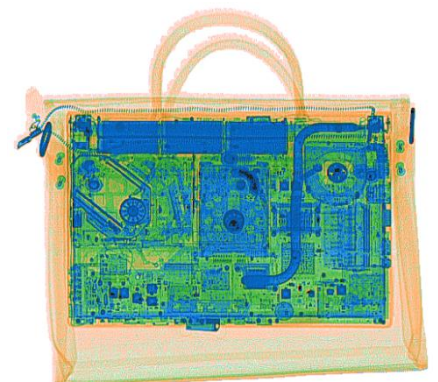
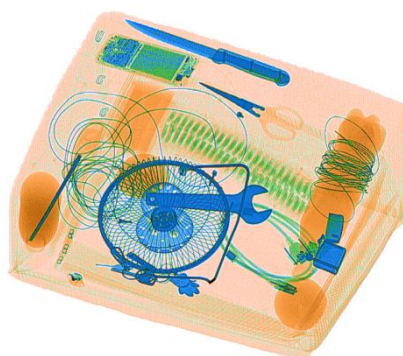
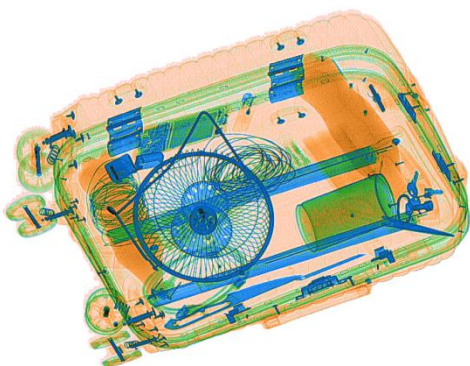

Functional characteristics

Power-on self-test	With the function of fault self-check, automatically judge the fault and prompt the fault code information in time.
Image processing	With the function of Color/BW, negative, high/low penetration, organic/inorganic stripping, general enhancement, and pseudocolor, etc.
Image Recall	30 preceding images recallable.
The number of images stored	Up to 10,00 images stored automatically.
Real-time curve	The real-time curve can be used to detect whether the acquisition system and components work normally.
Time setting	System time can be set
Probe setting	It can realize the manual deletion of the low and low energy detection board dead pixels, and display the deleted dead pixels in the display area.
Ray source setting	There are two source and analog source control modes, the source parameters of the digital source can be set.
Alarm system	The alarm function can be activated and deactivated, and the alarm type of the alarm box, sound and light alarm can be selected, and the sensitivity, minimum absorption rate, maximum absorption rate, and alarm duration can be set.
Troubleshooting	It can realize whether the components such as the entrance and exit light barrier, side panel switch, emergency stop switch and light source are normal, and display the standard value and current value of the detection voltage
Image setting	The drum running control direction and the image display moving direction can be set.
Software registration	It can realize software registration function and has serial number, registration code, registration status and system time information display.
User login	Log in by entering different user name and passwords, only when logging in can you make other settings.
User management	You can add, delete, edit the user name and password, set the user level to restore the deleted user.
Authority management	Different default permissions can be set according to user level.
language settings	The system language can be set to switch between Chinese and English.
Log management	User operations can be monitored to query user actions.
About	The version and device number can be displayed.
TIP report	The report can be generated by the tip operation after the tip insertion function is turned on, and the content of the report: user name, number of tip insertions, number of tags, false positive rate, probability of detection, probability of false positives.
Tip management	It can be set to enable and disable the insertion of dangerous goods, and can set the identification time, Prompt time, insertion frequency, proportion of single items inserted into dangerous goods, add tip files and delete files.
Document management	It can query, open, and export the checked image.
Function setting	It can set log level, save the file time, whether to open the training function and setting the smart roller.
Data setting	Display system working hours, the total working hours of the ray source, the total number of system baggage and packages, and the total number of baggage packages this time, and clear the above data.
System parameter setting	It can select the exported data, pictures, and backup directory, select and adjust the motor type, detector type, whether to enable the debug mode, model, and gain, enter the corresponding IP address on network connection to realize sharing function, and have corresponding software to achieve system upgrade.

Compliance

International	*ISO19001 ; SO14001 ; ISO27001 ; OHSMS18001 ; CE , ROHS, FCC, REACH, USA, FDA
National (China)	*Health Inspection Report *Computer Software Copyright Registration Certificate *Software Product Registration Certificate *Radiation Safety Certificate from Ministry of Public Security *Quality Certification from Safety and Police Electronic Products Quality Inspection Center *Design patent certification

SAFEMAN INSPECTION SYSTEM LIMITED

First Factory: Building A, QiFeng Digital Park, BaiNiKeng, PingHu Street, LongGang, Shenzhen, China
Second Factory: Building B, ShengLongXing Industrial Park, LongTeng Road, PingDi Street, LongGang, Shenzhen, China

Tel: +86 - 755-8934 2235 / Fax: +86 - 755-8934 2650

Mobile&Whatsapp: + 86- 136 7021 3490 Skype: sophia.xiong8105

Email: sophia@safeway-system.com

Website: www.safeway-system.com

