

## Product highlights

- \* Two generator, two view perspective dual energy imaging
- \* Automatic built in test and self diagnosis
- \* Secure access Key
- \* Uninterruptable power supply(UPS)
- \* Threat alert and material classification
- \* Auto arching
- \* Network-Ready
- \* Energy saving design
- \* One key turn off
- \* Drugs and explosives inspection
- \* Indication of the date and time

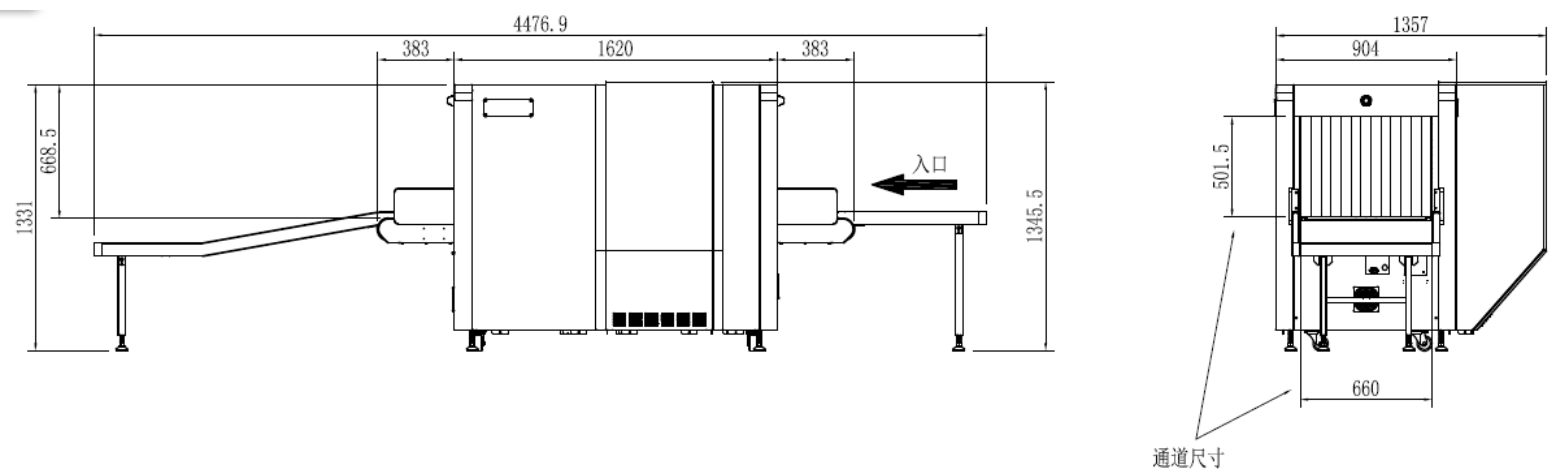

## Dimensional Drawing



## Important Sizes :

Product Size: 4476\*1537\*1345.5mm (L × W × H)

Tunnel Size: 660\* 510.5mm (width × height)

## Product Details

### General Specifications

Wire Resolution	Typical AWG38(top view); Typical AWG38(side view)
Penetration resolution	Typical AWG32(top view); Typical AWG32(side view)
Spatial resolution	Vertical:1.0mm, horizontal:1.0mm(top view); Vertical:1.3mm, horizontal:1.3mm (side view)
Penetration	34mm(top view); 34mm(side view)
Resolution of organic matter	34mm(top view); 34mm(side view)
Grayscale and mixture resolution	1 - 120 mm(top view); 1 - 120 mm(side view)
Resolution of inorganic objects	1 - 60mm(top view); 1-60 mm(side view)
Effective material resolution	0.2-14mm(top view); 0.2-14 mm(side view)
X-Ray dosage each inspection	Meet the requirements of GB15208.1-2005
Boundary Leakage	≤4. 8 μSv(uGy)
S/N ratio	≤0. 5 μSv /h(uGy/h)
Conveyor speed	<60dB
Conveyor max load	0.2m/s
Power consumption	150kg
Safety performance requirements	1.0KW
EMC requirements	Meet the requirements of GB15208.1-2005
Electrical safety	Meet the requirements of GB15208.1-2005
Environmental applicability	Meet the requirements of GB15208.1-2005
Leakage current	≤5.0mA
Film Safety	Guarantee ASA/ISO1600 Film
Weight	740kg
Operation temperature/Humidity	5℃-40℃/0%-90%
Storage temperature/Humidity	-20℃-60℃ /10%-90%
Atmospheric pressure	86kPa-106kPa
Operation Power	AC220V(±10%-15%) 50±3Hz
Operation system	Windows XP

### Configuration

X ray generator	160KV, oil cooling, from top to bottom
Electric roller	Three-phase
Computer	CPU: Intel Celeron 2.70GHz, Hard drive: 2T, Storage : 4G
Monitor	17" LED screen, resolution: 1280*1024 pixels
Operation console	Double screen console

### Scanned images

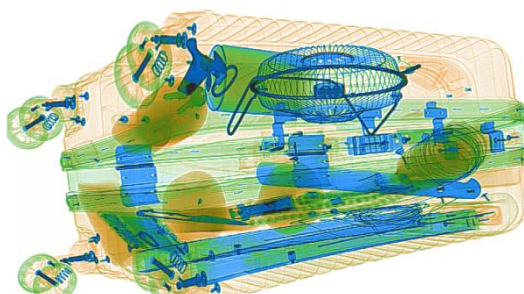
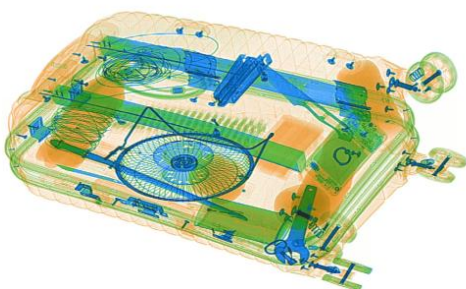

## Software Functions

Power-on self-test	With the function of fault self-check, automatically judge the fault and prompt the fault code information in time.
Image processing	With the function of Color/BW, negative, high/low penetration, organic/inorganic stripping, general enhancement, and pseudo color, etc.
Image Recall	30 preceding images recallable.
The number of images stored	Up to 10,000 images stored automatically.
Image management	With the functions of image information query, open, export and print, 6 image formats can be exported (JPG, BMP, XF, PNG, TIFF, GIF)
Operator management	Operators can be added and deleted, and operator names, groups, passwords, enabled status can be modified, and usage logs can be exported.
Dangerous goods image insertion	TIP insertion pictures can be added and deleted, TIP enable status, injection interval, floating range, motion determination time, and stationary determination time can be set; the user can check the operator by recording information.
Equipment diagnosis	Key components of equipment can be diagnosed through the diagnostic interface, including detector, motor positive and negative rotation, infrared sensor, special keyboard, etc.
System Settings	Programmable key, imaging display (horizontal, vertical image, maximum magnification, display recovery), scanning mode setting (two-way, direction, strong scanning, energy saving), auxiliary inspection (difficult to penetrate, explosives, drugs), luggage counter function Settings.
System equipment information	Display software version, equipment model, factory number, scan count, power on time, beam out time, image file storage capacity and other information. Able to conduct automatic through-baggage training for new operators.
Training function	Able to conduct automatic through-baggage training for new operators.

## Compliance

International	<ul style="list-style-type: none"> <li>* ISO19001 ; ISO14001 ; ISO27001 ; OHSMS18001 ;</li> <li>* CE , ROHS, FCC, REACH</li> <li>* USA, FDA</li> </ul>
National (China)	<ul style="list-style-type: none"> <li>* Health Inspection Report</li> <li>* Computer Software Copyright Registration Certificate</li> <li>* Software Product Registration Certificate</li> <li>* Radiation Safety Certificate from Ministry of Public Security</li> <li>* Quality Certification from Safety and Police Electronic Products Quality Inspection Center</li> <li>* Design patent certification</li> </ul>

### SAFEWAY INSPECTION SYSTEM LIMITED

First Factory: Building A, QiFeng Digital Park, BaiNiKeng, PingHu Street, LongGang, Shenzhen, China  
 Second Factory: Building B, ShengLongXing Industrial Park, LongTeng Road, PingDi Street, LongGang, Shenzhen, China  
 Tel: +86 - 755-8934 2235 / Fax: +86 - 755-8934 2650  
 Mobile&Whatsapp: + 86- 136 7021 3490 Skype: sophia.xiong8105  
 Email: sophia@safeway-system.com  
 Website: www.safeway-system.com

